

CLASS 125 FORGED BRASS NON-RISING GATE VALVE

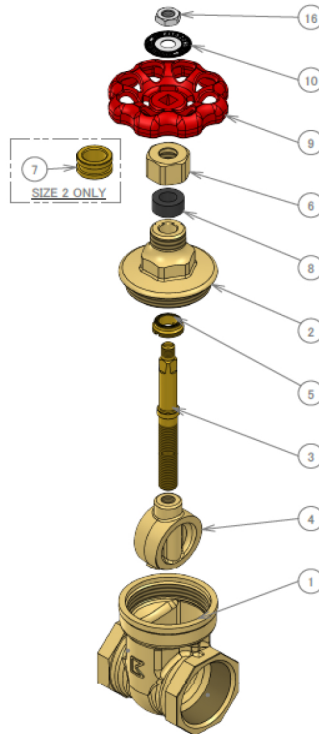
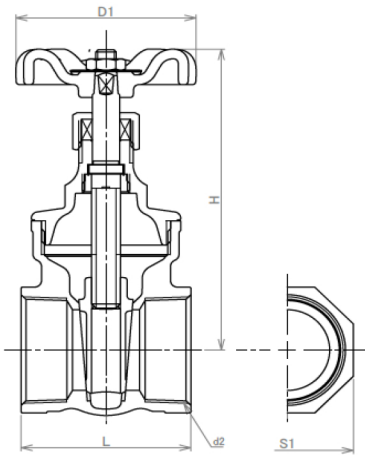

- ⚠ DO NOT USE FOR STEAM
- DO NOT USE UNDER FREEZE
- DO NOT USE FOR UNDERGROUND APPLICATION
- DO NOT USE FOR FLAMMABLE
- DO NOT USE FOR POISONOUS GAS APPLICATION
- WARRANTY ONLY APPLIES IN ASEAN

SPECIFICATION

- Forged Brass Body
- BSPT or NPT Threaded End
- Screwed Bonnet
- Nominal Pressure: 1.18 MPa
- Working Temperature: -10 ~ 120 °C

Note

- ※1 Dezincification Resistant Brass
- ※2 Aramid Fibers Graphite
- ※3 Aluminum Die-cast

MATERIAL LIST

No.	PART	MATERIAL
1	BODY	FORGED BRASS
2	BONNET	FORGED BRASS
3	STEM	BRASS ROD ※1
4	DISC	FORGED BRASS
5	LOCK NUT	FORGED BRASS
6	PACKING NUT	BRASS ROD
7	PACKING NUT	BRASS ROD
8	GLAND PACKING	GRAPHITE ※2
9	HANDWHEEL	ALUMINUM ALLOY ※3
10	WHEEL NUT	CARBON STEEL
16	NAME PLATE	ALUMINUM

SIZE	DIMENSIONS (mm)				d2
	L	D1	H	S1	
DN					BSPT or NPT
10	38	55	73	23	3/8
15	42	55	73	26	1/2
20	47	55	83	32	3/4
25	50	70	94	39	1
32	60	70	112	48	1.1/4
40	63	80	120	55	1.1/2
50	72	90	151	68	2

KITZ VALVE & ACTUATION (MALAYSIA) SDN. BHD.

<https://www.kitz-kvm.com/>

* All or part of the information listed on this sheet may be changed or removed without prior notice.